

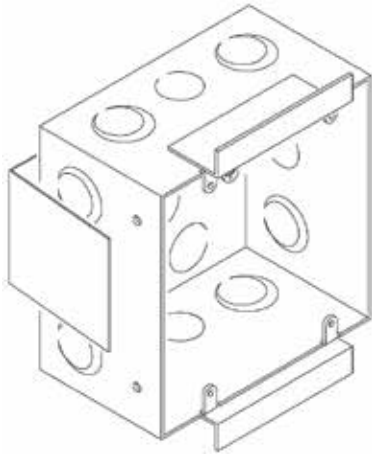

Making Communications & Fire Protection More Reliable and Cost-Effective!

Product Specifications:



Product Number R-55015-OW
5 SQUARE[®] Fire Signal Box (Old Work)

Product Description:
5 in. Square x 2.875" Deep Metal Box (Old Work)

Volume:
67 in³ (1098 cm³)

Side Knockouts:
(1) 1/2" & (2) 1/2" / 3/4" two sides only

Listing: C ETL US
Patented

Notes:

- Requires use of RANDL N-54012 Plaster Ring
- Requires use of Cooper Wheelock SFP Flush Plate (typical wall mount) or equal
- Maximum hole size for round appliances: 5" x 5"
- Verify minimum diameters of finished products prior to installation

Benefits of the 5 SQUARE[®] Roomy Design:

- Dramatically decreases the likelihood of ground faults and short circuits
- Saves hours of installation, start-up, and troubleshooting time
- Proven to be able to allow pass-through conductors, which may reduce conduit
- Reduces need for adjacent junction boxes
- Allows an upgrade to a speaker or chime strobe system without replacing the box if used on horn circuits; thereby, creating an easily upgradeable system for owners—with tremendous future cost savings!
- Proven to truly make the easiest and most cost-effective installation possible when using oversized voice evacuation signals
- The patented FIVE SQUARE backbox design provides an extension ring that reduces the opening to a standard 4 square

P.O. Box 14319
Spokane, WA. 99214-0319
Phone: (509) 340-0050
Fax: (509) 340-0051
www.randl-inc.com

